

HEAT BANK®



System Cables & Mats Radiant Heating

The Concept

One of the most comfortable and convenient forms of heating is the radiant heat from a building's concrete floor.

HeatBank® technology offers the comfort and benefits of the finest radiant heat system under the sun, combining the comfort of radiant heat with the cleanliness and consistency of electricity. Converting electrical energy into a reservoir of radiant warmth, HeatBank can easily and efficiently heat industrial, and commercial structures.

HeatBank is an electric heating system that uses a building's foundation and the ground below it to store heat. Electricity is converted to heat using a specially designed electrical resistance cable buried in a sand bed beneath the floor slab. The cable can be formed into a mat at the Easy heat factory, or supplied directly to the site on spools for placement into the sand bed. Contained in a storage reservoir formed by insulating the foundation perimeter, the heat radiates through the slab into the interior of the building. Radiant heat provides a uniform level of comfort that is clean, maintains natural humidification and eliminates heat stratifications within the space.

The inherent economies of the concept are often further enhanced by utility-sponsored load management programs. Many electric utilities offer seasonal and/or off-peak rates in an effort to more effectively utilize generating capacity sized for larger summertime loads, or to shift their electrical load from heavy daytime usage to a period when demand is considerably lower. By shifting this load, the power companies use their generating capabilities more efficiently during low consumption (off-peak) periods. There are typically very attractive rates for qualifying off-peak loads such as HeatBank. This can also reduce the need for utilities to construct new generating facilities.

HeatBank should not be used as a primary source of heat for a building. This is because the system is buried under the building floor, and can not be serviced, should the need arise. While the HeatBank system will last for many years, a separate building heat source that can be serviced and replaced as required must be installed when the building is constructed.

Planning

Your decision to install HeatBank begins a close relationship with EasyHeat Inc. To ensure the best possible application, we will analyze your situation and offer suggestions to increase the energy efficiency of your building. For instance, **a heat loss in excess of ten per square foot is a sign of inadequate insulation. It is false economy to save a few dollars on this one-time cost and pay a substantially higher heating bill for the entire life of the structure.** Also, if after reviewing the building's design we determine that HeatBank is inappropriate for your needs, we will discuss heating alternatives.

The following information is necessary to determine feasibility:

- Building heat loss (Easy Heat can also do a heat loss analysis)
- Proposed number of zones and heat loss for each zone
- Intended use of the building
- Length, width and height of the building
- R-Value of wall and roof insulation
- Number, sizes and R-Values of doors and windows
- Lowest expected ambient temperature
- Building maintenance temperature

- Number of off-peak hours available per day
- Available voltage and amperage

Your EasyHeat representative is the liaison between you the customer, your local utility provider, and our factory. Just provide your representative with the above information. We'll furnish a bill of materials and a drawing showing the number and positioning of HeatBank mats/cables required for your job. Your representative will also provide job-site consultation.

The installed capacity of HeatBank mats/cables must exceed the building heat loss to account for the reduced time period that the system is operated ("charged") each day, as follows:

Charging Time (Hours)	Heat Loss Multiplier
8	1.5
12	1.2

For a building with a heat loss of 10 W/sq.ft. and a charging time of 8 hours, an installed capacity of 15 W/sq.ft. of HeatBank mats/cables would be required.



Figure 1

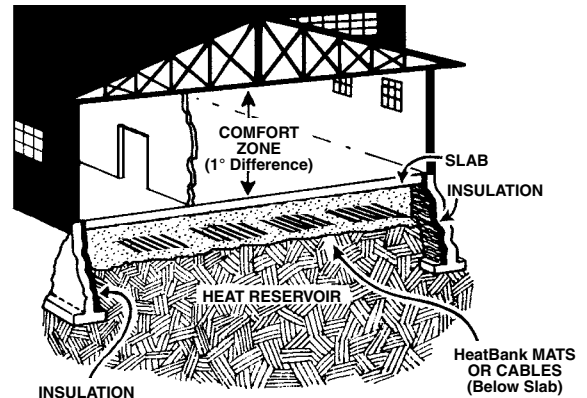

Site Preparation

For maximum efficiency the following is recommended:

- Utilize a tightly compacted, moist sand base of at least 4" depth, although, typically, sand beds are 10" to 12" deep. All underground plumbing and electrical utilities shall be routed in the sub-base and backfilled with well compacted material. Structural footings, walls, piers, etc., adjacent to or within the sand bed must be completed.
- Using sand bed depths of up to 18"; sand depth is determined by the building design and geographic region.
- The cables/mats must be positioned with at least 2" of compacted sand above and below.

A scaled drawing should be made showing the layout for the heating cables/mats, related branch circuitry, junction boxes and controls. **Retain this drawing for future reference, as warranty is void without this drawing.**

Prepare the sand storage bank according to plans and specifications. Generally this will require the following:

- Area to be heated to a level of 10" to 12" below underside of slab.
- Remove stones or any other debris that may be present. Such material can cause the cables/mats to overheat.
- Cover the graded area with a minimum of 2" of compacted, washed masonry sand, to provide a base for the heating cables/mats.

See Figure 2

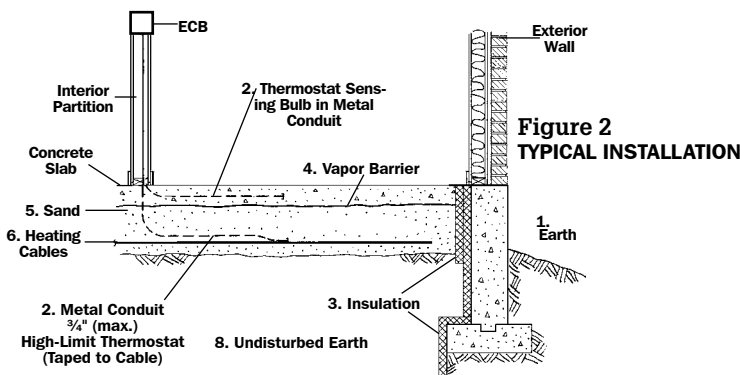

- External grade level should be near top of foundation.
- High limit thermostat sensing bulb in conduit.
- FOUNDATION WALLS MUST BE INSULATED.** Insulation must be 2" rigid styrofoam type SM or equivalent rigid closed cell extruded polystyrene. Extend to a depth below finished floor of at least 4' to reduce side heat loss. Where external grade doesn't reach level of floor (such as at a loading dock), insulation should be wrapped around footing and continue downward without disturbing soil bearing.
- Vapor barrier.
- Sand depth of 10" to 12" must be free of stones and organic matter and well compacted to provide a stable base for the slab.
- Heating cables/mats – spaced as specified on individual job drawing (see Spacing Chart).
- Slab temperature thermostat sensing bulb in conduit.
- The sub-base below sand bed can be sand, gravel, clay, engineered backfill, or native soils free of organic matter. Natural ground moisture or infrequent high water doesn't adversely effect the system, **but moving water such as underground springs, tidal functions, or continuous standing water, will significantly reduce system efficiency.**

Figure 3
BASIC HEATBANK CONTROL
(Typical Each Zone)

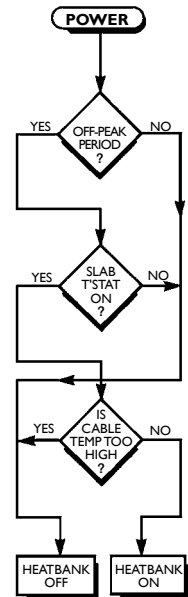

INSTALLATION INSTRUCTIONS ARE PROVIDED WITH EACH CABLE/MAT — FOLLOW INSTRUCTIONS CAREFULLY

Installation

Prior to installing cables/mats, locate metal conduit for thermostat and high limit sensing bulbs as well as the cable cold leads. Use conduit where cold leads exit the sand bed and ensure that a bushing is installed where cold leads enter conduit.

For spooled cable, fill the graded area with the design thickness of compacted sand. For mats, cover the graded area with about one third of the design thickness of the sand bank, but not less than 2". **USE ONLY WASHED MASONRY SAND FOR THE STORAGE BANK.**

- TEST CABLES/MATS FOR CONTINUITY AND INSULATION RESISTANCE USING A 500V MEGGER PRIOR TO UNSPOOLING.** Minimum insulation resistance reading between conductor and ground braid is **10 megohms**.
- Install spooled heating cables in sand as per spacing from Spacing Chart. For mats, lay mats onto sand. Ensure that cables/mats are not damaged during installation. Don't pull or bend cold lead factory splice. Care must be taken that cable doesn't bunch, kink, twist or overlap. Each spooled cable has a marking indicating the midpoint of the cable to use as a benchmark during the installation.
- Don't install heating cable within 6" of any obstruction, such as plumbing, drains, conduits, structural members, etc.
- The entire heating cable, including the cold lead factory splice, must be embedded in the sand at a uniform depth and must be installed with uniform spacing.
- Install 3/4" (maximum) rigid metal conduit for high limit thermostat. Close terminal end of conduit with threaded metal pipe plug or cap such that sensing bulb can be fully inserted to dead end. Attach the final 3" to 6" of conduit directly to a heating cable using vinyl electrical tape (**DO NOT USE TIE WRAPS**). Choose a point of attachment:
 - At least 2 feet into the heating cable array.
 - Within the range of the 10-foot capillary tube.
 - That requires a single 90° conduit elbow/bend. (Multiple bends will impede bulb insertion.)
- Install cold lead conduit(s) and pull cold leads through conduit. Identify all cold lead pairs. If factory labels are removed from cold leads, they shall be affixed to the branch circuit panel to identify the pertinent supply circuits.
- Complete sand cover over mats, taking extreme care not to damage cable.
- Compact sand to provide a homogenous, stable base for the slab.
- IMMEDIATELY PRIOR TO CONCRETE POUR, RETEST CABLE FOR CONTINUITY AND INSULATION RESISTANCE.** Due to the proximity of heavy machinery to the heating cable during cable installation and subsequent floor placement, there are risks of cable damage by such machinery. Workers must be cautioned to report any possible cable damage immediately so that necessary repairs can be made prior to completion of the pour. All repairs must be in compliance with standards established by the applicable code enforcement authorities.
- Prior to the concrete pour, wet sand with a fine water spray to further compact the sand. Continue to wet sand until fully and evenly saturated with water.
- Install vapor barrier atop sand bed. Overlap sheeting at least 6". Apply additional sand (1") on top of vapor barrier to ensure adequate securement.
- Install 3/4" (maximum) rigid metal or intermediate metal conduit for floor sensing thermostat. Close terminal end of conduit to exclude concrete and situate at the mid-level of the slab directly above the heating cable array and within the range of the 10-foot capillary tube.

13. **IMMEDIATELY AFTER CONCRETE POUR, RETEST CABLES/MATS FOR CONTINUITY AND INSULATION RESISTANCE TO ENSURE THAT NO DAMAGE HAS OCCURRED DURING POUR. DO NOT ENERGIZE CABLES/MATS AT THIS TIME.**
14. Allow minimum of 2 weeks for concrete to cure prior to energizing cables/mats.
15. All wiring and installation of electrical equipment and devices comprising the Deep Heat system shall be in accordance with all requirements of the National Electrical Code and all applicable local electrical and building codes, regulations, and inspection procedures.

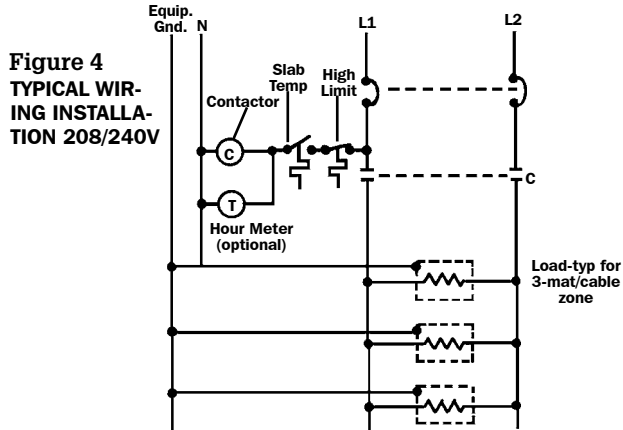

16. The copper ground braid on each cable must be connected to a suitable equipment grounding conductor per article 250 of the National Electrical Code.
17. Install thermostats, ensuring sensor bulbs are fully inserted into their respective conduits. Whether used for switching duty or pilot duty, the two thermostats associated with each heating zone should be wired in series.
18. Connect power to system.

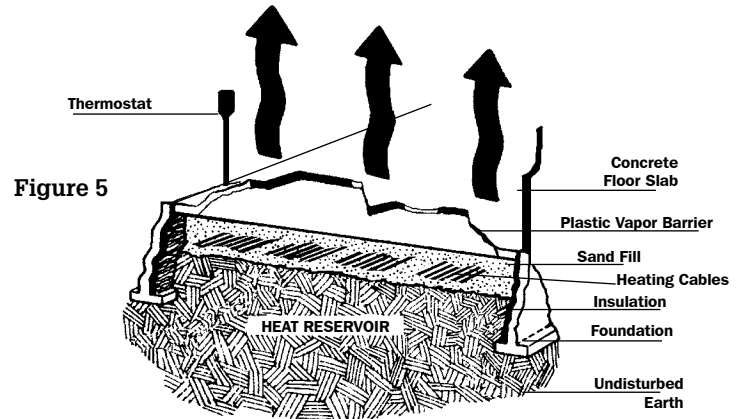

Operating Tips

At the beginning of the heating season, it may take a few days for the sand bank to become fully charged. Avoid placement of thick carpets or low clearance furniture on the concrete floor, as these will impede the flow of the heat up through the floor.

Electrical Tests

The electrician must perform certain electrical tests on each mat as installation progresses. It is important that these tests be performed and the results recorded for future reference. An **INSTALLATION TEST RECORD FORM** is provided with the installation instructions. A completed copy of the form must be returned to the factory to register the installation.

Concrete Considerations

Although slab thickness may vary depending on the intended use of the building, consider 6 inches to be average. Prepare the slab following the guidelines of American Concrete Institute Publications ACI 308-81 and ACI 302.1R-80.

Once the slab is cured, it may be sawed or drilled as long as care is taken to avoid the sensing bulb locations. Cutting or drilling operations must not extend into the heat storage reservoir.

LIMITED WARRANTY

Easy Heat, Inc. warrants to you, the original purchaser only, that if there are any defects in material or workmanship in any HeatBank mat or cable during the first ten years after the date of its purchase, we will refund a portion of the purchase price you paid for the mat or cable, as follows:

If the defect arises during the first two years after the date of purchase, we will refund 100% of the purchase price you paid. If the defect arises after the second anniversary of the date of purchase but on or before the fifth anniversary of the date of purchase, we will refund a percentage of the purchase price you paid equal to 100%, less 20% for each full or partial year since the second anniversary of the date of purchase until the fifth anniversary of the date of purchase, and less an additional 7% for each full or partial year since the fifth anniversary of the date of purchase until the tenth anniversary of the date of purchase.

Our obligation to refund the portion of the purchase price described above is conditioned upon each of the following statements being true:

1. The installation of the mat or cable, the construction of the building, the insulation materials and methods and the supplementary heat and controls shall have conformed to the specifications set forth in our literature.
2. The mat or cable shall have been connected to a proper supply voltage source, which shall not have deviated from its nominal rating by more than 5%.
3. All wiring shall have conformed to the current National Electrical Code and shall have been installed by a licensed electrical contractor.
4. There shall have been no increase in the original heat loss.
5. All thermostats, time clocks and other system control devices shall have been installed properly and checked at the start of each heating season.

A refund of your purchase prices as described above shall be your sole and exclusive remedy for a breach of this warranty. This limited warranty does not cover any costs relating to the repair or replacement of any mat or cable. Our mats and cables are embedded in several inches of sand, and then covered with several inches of concrete, upon which are constructed walls, flooring and other decorative elements. Often a failed mat or cable cannot be repaired. Replacement of a failed mat or cable requires that your home or building be vacated while your walls, flooring and other decorative elements are removed to permit the demolition of the concrete slab. After replacement of the failed mat or cable, your walls, flooring and other decorative elements must be replaced and your home or building may require extensive cleaning. Repairing and /or replacing a failed mat or cable is very difficult and expensive. You must consider the possible necessity of changing, for a variety of reasons, to an alternative energy source at some time in the future as a failed mat or cable may not be repairable and the cost of replacement may be prohibitive. Any costs relating to the repair or replacement of any mat or cable will be your responsibility.

We shall not be liable for any incidental, special or consequential damages as a result of any breach of this warranty or otherwise, whether or not caused by negligence. Some states do not allow the exclusion or limitation of incidental or consequential damages, so the above limitation or exclusion may not apply to you.

We make no other express warranty regarding any HeatBank mat or cable. No affirmation of fact or promise made by us, by words or action, shall constitute a warranty. If any model or sample was shown to you, the model or sample was used merely to illustrate the general type and quality of the goods and not to represent that the goods would necessarily be of that type or nature. No agent, employee or representative of ours has authority to bind us to any affirmation, representation or warranty concerning the goods sold unless such affirmation, representation or warranty is specifically incorporated by written agreement.

We disclaim all implied warranties, including warranties of merchantability and fitness for any particular purpose, unless we are prohibited by law from doing so, in which case all such implied warranties shall expire at the earliest time permitted by applicable law. Some states do not allow limitations on how long an implied warranty lasts, so the above may not apply to you.

This warranty gives you specific legal rights, and you may also have other rights which vary from state to state.

To obtain a refund under this warranty, please send a description of the defect and proof of purchase, postage paid, to Easy Heat, Inc., 2 Connecticut South Drive, East Granby, CT 06026.

XD Cable

Easy Heat's new high wattage dual conductor earth thermal storage cable is a tough, heavy duty heating cable that is designed and UL Listed specifically for earth thermal storage applications. The dual conductor, single end cold lead cable design means easier heating system design and installation. Only one end needs to be routed to the power source. With a nominal output of 8 watts per foot, the cable is now easier than ever to design.

Site preparation, control and installation in the sand bed are the same as for mats except that the installer is responsible for maintaining the proper distance between runs. Spacing between runs is determined by heat-loss requirements.

Chart 1—Spacing Chart
STORAGE CAPABILITY AT TYPICAL CABLE SPACINGS

Cable Spacing	Watts Per Square Foot	
	@240V	@208V
4"	24	18
6"	16	12
8"	12	9
10"	9.6	7.2
12"	8	6

Minimum spacing between cable runs is 4".

Figure 6
HEATER WIRE

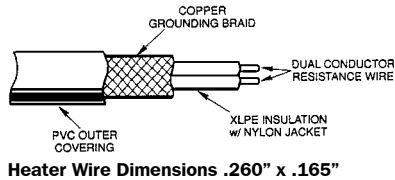

HEAT SHRINK HOT TO COLD SPLICE

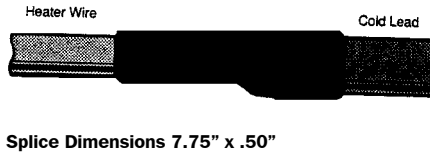

COLD LEAD

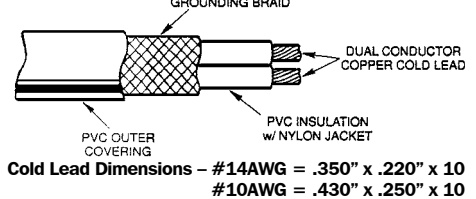

Install the high-limit thermostat so that it measures the temperature near the center of the cable run. Perform all electrical tests as described in the installation section of this guide. All wiring and installation must be done in accordance with UL requirements, the most recent edition of the National Electrical Code, and all local codes and specifications.

Chart 2
XD CABLE SPECIFICATIONS

Catalog Number	Length (in feet)	Nominal Wattage 240V**	Nominal Amperage 240V**
XD102	126	1000	4.2
XD152	190	1500	6.3
XD202	253	2000	8.5
XD252	303	2500	10.4
XD302	369	3000	12.5
XD352*	435	3500	14.7
XD402*	495	4000	16.7
XD502*	661	5200	21.9

* Indicates those cables using #10AWG Cold Leads; all others use #14 AWG. Standard cold lead length is 10 feet.

** For 208 volt operation, multiply by .75.

Standard cables are designed for 240 volt operation.

HeatBank® Mats

Please contact your local factory representative or Easy Heat Inc. with questions about HeatBank mats.

Chart 3
36" HEATBANK MAT SPECIFICATIONS
(ALL MATS 22 WATTS PER SQUARE FOOT)

Cat. No.	Lgth. Feet	Watts	Amps (Nominal)			
			208V	240V	277V	480V
DH*-5.5	5.5	363	1.75	1.51	1.31	0.76
DH*-11	11	726	3.50	3.03	2.62	1.51
DH*-15	15	990	4.76	4.13	3.57	2.06
DH*-18	18	1188	5.71	4.95	4.29	2.48
DH*-22	22	1452	6.98	6.05	5.24	3.03
DH*-27	27	1782	8.57	7.43	6.43	3.71
DH*-33	33	2178	10.47	9.08	7.86	4.54
DH*-36	36	2376	11.42	9.90	8.58	4.95
DH*-44	44	2904	13.96	12.10	10.48	6.05
DH*-48	48	3168	15.23	13.20	11.44	6.60
DH*-55	55	3630	17.45	15.13	13.11	7.56

*Voltage Codes: 8 = 208V; 2 = 240V; 7 = 277V; 4 = 480V.

Figure 7

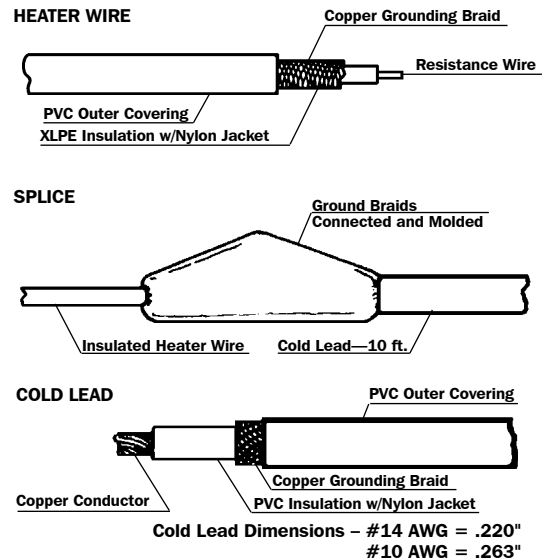

USA
2 Connecticut South Drive
East Granby, CT 06026
Tel. (800) 537-4732
Fax (888) 324-2440

CANADA
99 Union St.
Elmira, Ont. N3B 3L7
Tel. (519) 669-2444
Fax (519) 669-6419

www.easyheat.com